



AOXIANG
ELECTRIC INTELLIGENT ACTUATOR
ELECTRIC VALVES



AOX-Q-L Electric Actuator

Patented products,
Counterfeiting not allowed

ZHEJIANG AOXIANG AUTO-CONTROL TECHNOLOGY CO.,LTD

Add: No.31 Hua'an Road, Nanbin Street, Rui'an City,
Zhejiang Province, China 325207
Tel: +86-577-65151268
Email: zjaox@zjaox.com
Http: //www.aoxactuator.com

AOX-Q-L Electric Actuator

Patented products,
Counterfeiting not allowed





AOXIANG
ELECTRIC INTELLIGENT ACTUATOR
ELECTRIC VALVES

Catalogue

Company Profile -----	01
Cases and certificates -----	02
Product Overview -----	03
Description-----	03
Working Environment -----	04
Basic Control Methods -----	05
Control Functions -----	05
Simple and Clear Operation Mode -----	07
Product Features -----	09
Bus Control -----	13
Product Specifications-----	17
Standard Parameters -----	17
Appearance Drawing -----	18
Solutions for Special Applications -----	18

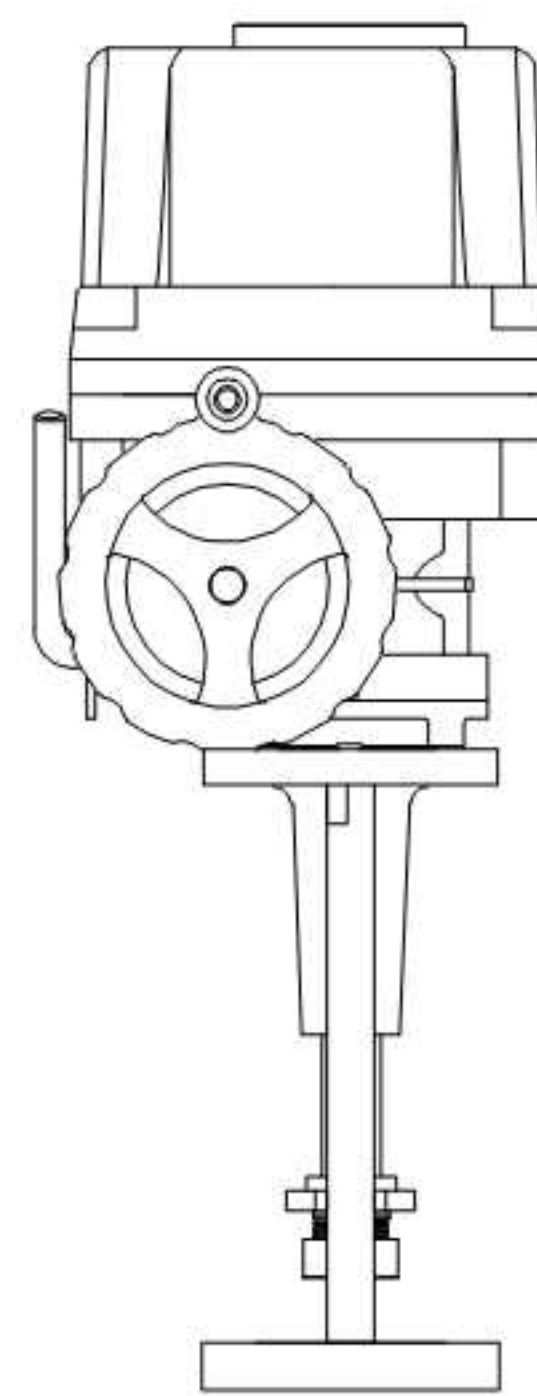

AOX-Q-L Electric Actuator

Patented products,Counterfeiting not allowed.

AOX was founded in 1997. With decades of profound understanding of products and rich industrial application experience, rigorous manufacturing process and modular precision design, AOX provides the most professional automatic control products and solutions for various severe working conditions (such as military, nuclear and other fields). Whether in harsh environments or under various operating requirements specified by users, AOX actuators can not only meet high safety standards, but also prove the reliability and robust design of their products.

AOX has always focused on the modular design of products. The diversified components ensure that the products can be assembled according to customer needs, and provide various customized products to meet customer needs.

Field Case



Electric Power



Petroleum



Chemical industry



Water treatment



Food field



Metallurgy

Honors and qualifications

- First tier supplier of CNPC
- Sinopec Supplier
- National Specialized and Innovative Small Giants
- National Intellectual Property Advantage Enterprise
- National high-tech enterprises
- National Technological Innovation Fund for Small and Medium sized Enterprises
- National Torch Plan Industrialization Demonstration Project
- Provincial High tech Enterprise Research and Development Center
- Provincial science and technology new products
- Provincial Science and Technology Progress Award
- Provincial patent demonstration enterprise
- AAA Credit Enterprise
- WenZhou specialized, special and new key supporting enterprises
- WenZhou Famous Brand Products
- EU CE certification
- DNVGL certification
- CCS certification
- ATEX certification
- SIL3 certification
- CCC certification
- ISO9001 / ISO14001 / ISO45001

Product Overview

The "AOX-Q-L" series is compact, provides manual and automatic clutching, and is extremely weather and vibration resistant. In the event of actuator power failure, the self-locking drive mechanism ensures the valve position remains unchanged, and electrical limits are set to prevent overtravel. Widely used in linear action valve switching and regulating control, such as gate valve, globe valve, regulating valve, etc., widely used in various industries such as petroleum, chemical, water treatment, shipping, paper, power station, heating, building automatic control, etc.

Description

- Torque range: 2000~40000N
- Ex d II CT4 Gb/Ex tD a21 IP67T95°C explosion-proof housing available (ATEX type optional)
- DNVGL、CCS、ATEX、SIL3、CU-TR、CE、CCC
- Basic control mode:
 - ON-OFF MODEL
 - MODULATING MODEL
 - CONTINUOUS MODELING MODEL
- Different control types are available according to customer requirements:
 - ON-OFF TYPE
 - MODULATING TYPE (PCU)
 - NON-INVASIVE INTEGRATED TYPE (SRCU)
 - FIELDBUS TYPE(ICU+SINGLE/DOUBLE CARD+ FIELDBUS NAME)
- Solutions for special applications:
 - Split type
 - Power off reset
 - Internet of Things



Working Environment

- Sealing protection ----- Conforms to GB/4208-2017 standard, IP67 (standard, all connection surfaces are set with O-ring seal) protection level, available Optional IP68 (double O-rings are set on all connecting surfaces).
- Explosion protection level----- According to GB/3836, IEC, CU-TR standard, Exd design. ATEX, CCC certification, meet all potential in explosive environments (such as oil, gas, chemical, power, metallurgy and the emerging gas industry, etc.).
- Anti-corrosion protection ----- Is anodized and polyester powder coated, standard color is AOX grey (similar to RAL7039), corrosion resistant Strong corrosion resistance, suitable for working conditions such as industrial corrosive environment (chemical, alumina plant) or marine corrosive environment (offshore/sea).
- Ambient temperature----- Standard:
 - ON-OFF TYPE, MODULATING TYPE (-30 °C~+75 °C)
 - INTELLIGENT TYPE, NON-INVASIVE INTEGRATED TYPE (-25°C~+70°C)
 Low temperature:
 - ON-OFF TYPE, MODULATING TYPE (-60°C~+50°C)
 - INTELLIGENT TYPE, NON-INVASIVE INTEGRATED TYPE (-60°C~+60°C)



Basic Control Methods

According to EN 15714-2 standard, to meet different application conditions and designs, there are three basic control methods as follows

Type I On-Off type

The actuator drives the valve from fully open to fully closed or fully closed to fully open.

Type II Modulating Type

The actuator sometimes needs to drive the valve to any position (fully open, midway position and fully closed).

Type III Continuous Modulating Type

The actuator frequently drives the valve to any position between fully open and fully closed.

For continuously adjustable actuators, the number of starts allowed and the load conditions are additionally referenced to the characteristics.

The on-off type or modulating type is selected according to the different mechanical loads of the actuator. Therefore, each actuator type can be used in various operating modes.

	On-Off type	Modulating Type	Continuous Modulating Type
Working mode	S2-15min/30min	S4-25%~50%	S4-75%~100%
Model Name			
Applicable control functions	Fieldbus Type	ICU+Modbus/Profibus/Hart	Continuous Modulating Type
	Intelligent Type	ICU	Continuous Modulating Type
	Non-Intrusive Intelligent Type	SRCU	/
	General Type	On-Off type	PCU

Note: the number "1" after the model represents the voltage AC 1ph; "2" stands for voltage AC 3ph; "3" represents voltage DC, such as SRCU2 (AC 3ph Non-Invasive Integrated Type)

Control Functions

AOX actuators can be integrated into any automation system and it is advisable to choose an actuator with more than non-intrusive integrated functions during the product selection phase, thus saving a lot of time in project planning, installation and documentation required to select external controls. AOX offers a wide range of control functions, so customers can choose the best solution for their needs.

Intelligent Type (ICU)

The ICU control system has comprehensive configuration capabilities for all actuator control functions and supports many different fieldbus controls.

LCD display

- ▶ Digital display of opening percentage, accurate to 0.1%
- ▶ Valve position can still be displayed locally when the power is off (optional)
- ▶ Fault self-diagnosis function display, such as: **valve position error**, **torque overload**, **motor overheating**, etc.

Non-Intrusive commissioning

- ▶ Infrared remote control: convenient for remote operation and setting various functions
- ▶ Menu setting by field control knob or remote control

Electronic torque (Optional)

- ▶ Torque range adjustable, display running torque, percentage form display

Absolute encoder

- ▶ No battery support, high precision recording of valve position

ESD function

- ▶ In case of emergency, the ESD signal can override any on-site or remote signal (according to the parameter setting) to force the actuator to close or open the valve.

Fieldbus control (Optional)

- ▶ Many different fieldbus systems, such as Profibus, Modbus, Hart, FF, etc



Non-Invasive Integrated Type (SRCU)

When the application requires adaptive control function, configurable user interface or intelligent diagnostic function requirements, the choice of non-invasive integrated function will be the perfect solution.

LCD display

- ▶ Chinese/English switch(optional), Digital display of opening percentage
- ▶ Valve position can still be displayed locally when the power is off(optional)
- ▶ Fault self-diagnosis function display, such as: **valve position error**, **torque overload**, **motor overheating**, etc.

Non-Intrusive commissioning

- ▶ Infrared remote control(Optional): convenient for remote operation and setting various functions
- ▶ Menu setting by field control knob or remote control

Electronic torque(Optional)

- ▶ Torque range adjustable, display running torque, percentage form display

Absolute encoder

- ▶ No battery support, high precision recording of valve position

Status indicator

- Full Open
- Full Close



Modulating Type (PCU)

Signal setting

- ▶ Input (setting) and output (feedback) signals are completely isolated.
- ▶ Input/Output: 4-20mA(standard) Input impedance 160Q
- ▶ Input/Output: 0-10V, 1-5V, 0-20mA, etc. (optional)

Analog output

- ▶ Current: Maximum acceptable load is 750Ω at 24VDC supply
- ▶ Voltage: Minimum acceptable load is 50KΩ (shunt resistance 500Ω)

Adjustment accuracy

- ▶ Factory standard accuracy 0.7%
- ▶ Accuracy 0.2%~0.5% can be set

ON-OFF Type

Position indicator

- ▶ Transmission is self-locking at all speeds
- ▶ Continuous gearing from motor to valve
- ▶ Main mechanical parts have good vibration resistance

Indicator

- ▶ Indicator mounted on the support shaft for easier observation
- ▶ Indicator shows continuous position change even in case of power failure



In addition to the above functions, if you have other needs, please contact us.



AOX pays special attention to the development of user friendly interfaces. For intelligent type(ICU), a clear and intuitive user interface makes it easier to store and retrieve actuator data.

1 LCD

The LCD interface is designed according to the user's vision and operation habits, and is displayed in plain text, with Chinese/English available for users to choose.

2 Status indicator

The indicator light is used as a visual signal to display the status information of the actuator, and it can be freely programmed and configured according to requirements. Even if viewed from a distance, the ignition of the LED indicator light is clear and recognizable.

3 Selection of control mode

The local control knob (LOCAL/STOP/REMOTE) installed on the local operation device can be used to set the remote operation (remote control) or local operation [local control] mode.

4 Operation and parameter setting

According to the selected switch position, the local control knob (LC/LO) can be used to start electric actuator operation, status request, menu navigation and other functions.

5 Display of valve position

Even if viewed from a distance, the valve position can still be clearly seen through the crystal display interface of super large liquid.

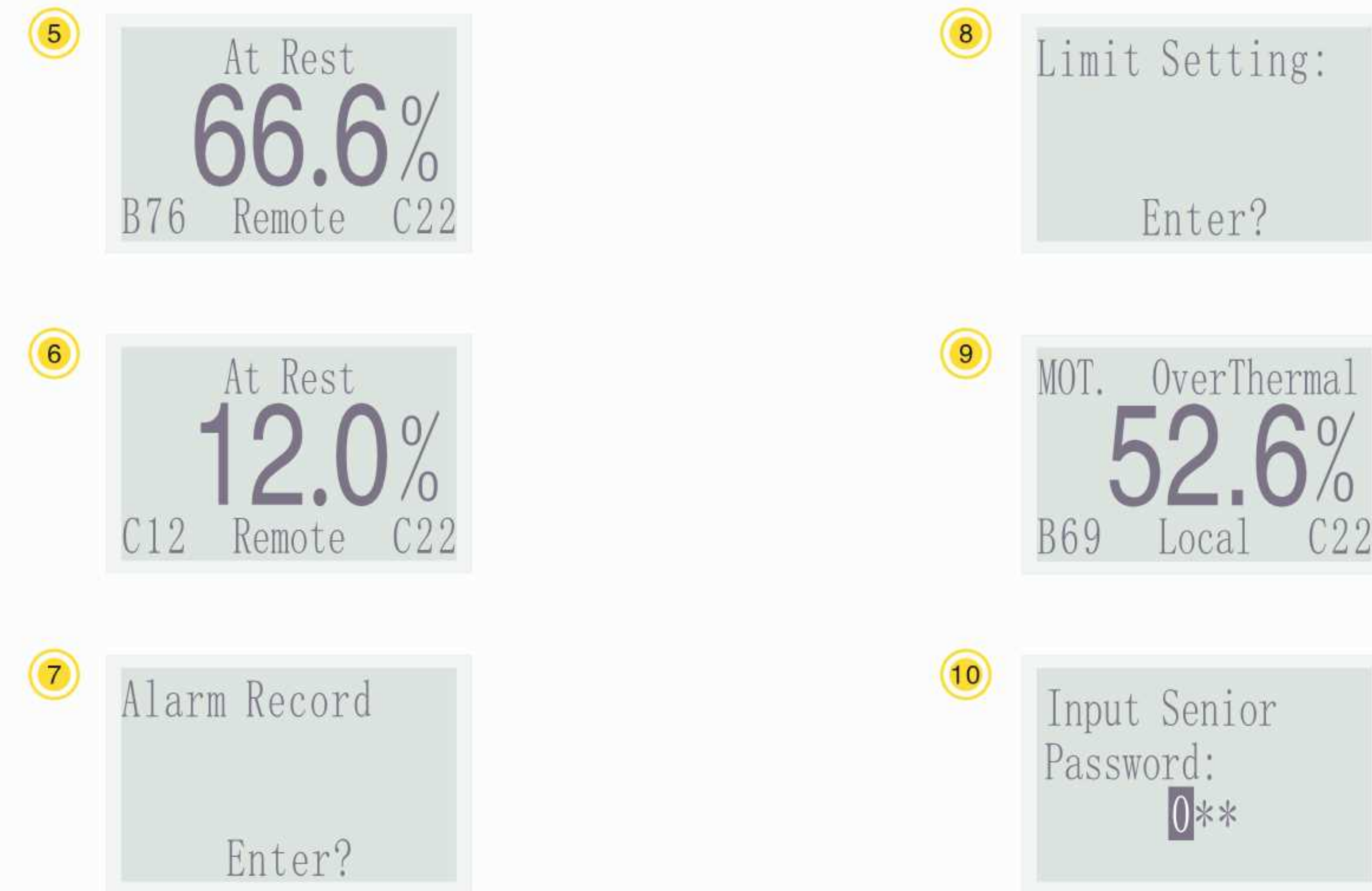

6 Display of operating commands/set points

The operation command and set point sent by DCS system can be displayed through LCD display interface.

7 Display of diagnosis/monitoring

During equipment operation, environmental conditions and operation status are continuously monitored. When the allowable range is exceeded, such as operation time, the intelligent control unit (ICU) will generate a warning signal.

8 Non intrusive setting

The actuator equipped with a high intelligent control unit can be set through the local control knob or remote controller without opening the actuator end cover.

9 Fault display

In case of any fault, the fault cause can be inquired through the LCD interface.

10 Password protectio

The intelligent (ICU) has perfect 3-level password protection, which can authorize different customers or operators separately to prevent actuator failures caused by wrong parameters.

All parameter settings of the device do not require any other setting tools.

Product Characteristics

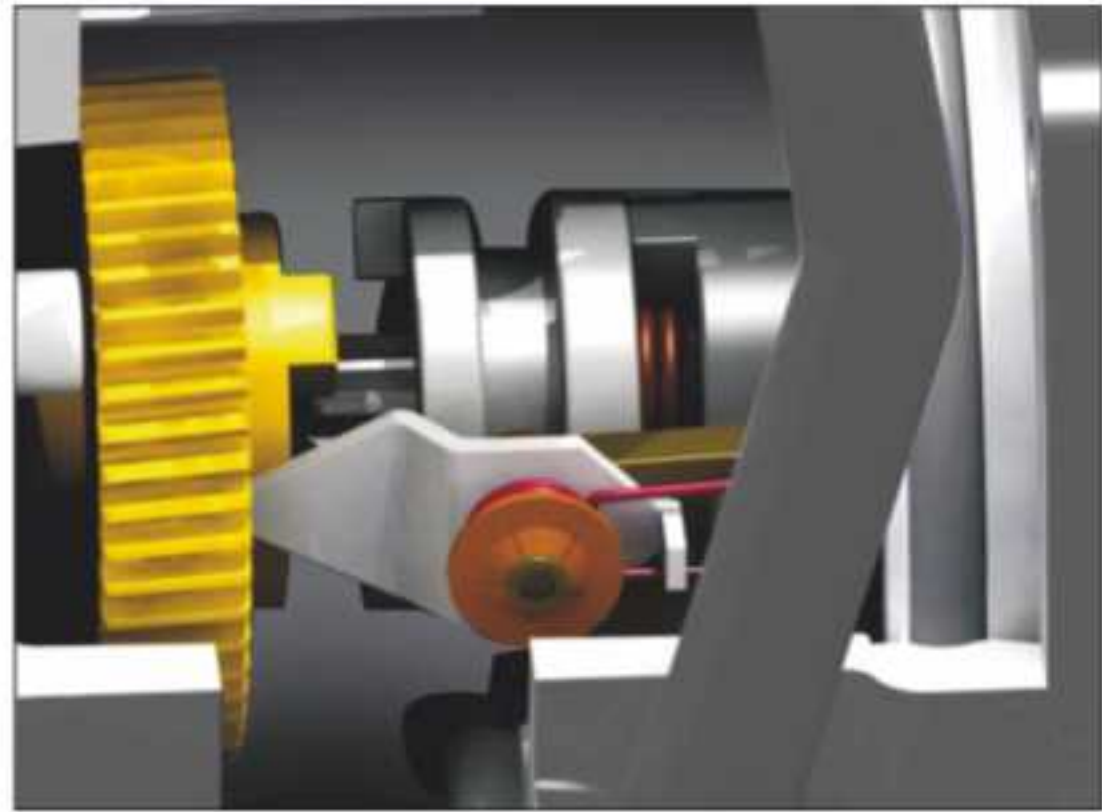

Manual override

- Auto / Manual switchable lever and handwheel engagement for emergency manual operation.
- Drive force automatically resorted by motor start, unless lever padlocked to prevent this occurring.



Limit switches

- It is fastened by the two screws above, the setting is simple, each cam can be set separately.
- Once the setup is complete, each cam will always remain in this position.



Terminal

- Spring loaded push type terminal for tight wiring connection under severe vibration.
- The number of terminals are 22 for users.
- Terminal length: 8-9mm
- Terminal size: 10*22*32



Heater

- It is used to control the temperature, prevent moisture condensation in the actuator due to temperature and weather changes, and keep the internal electrical components dry.



AOX-Q-L Electric Actuator

Patented products, Counterfeiting not allowed.

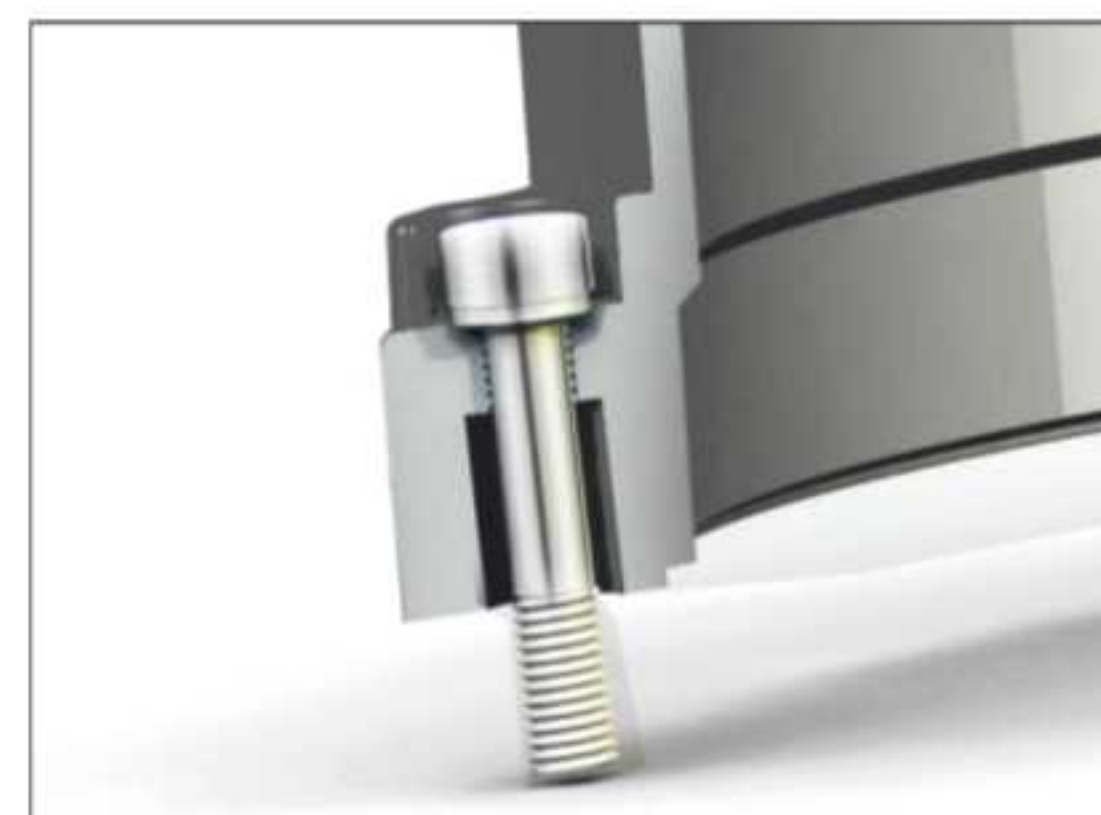

Anti falling bolt

- The upper cover bolts are specially designed to prevent them from falling off during maintenance and installation. All external bolts are made of stainless steel and will not rust.

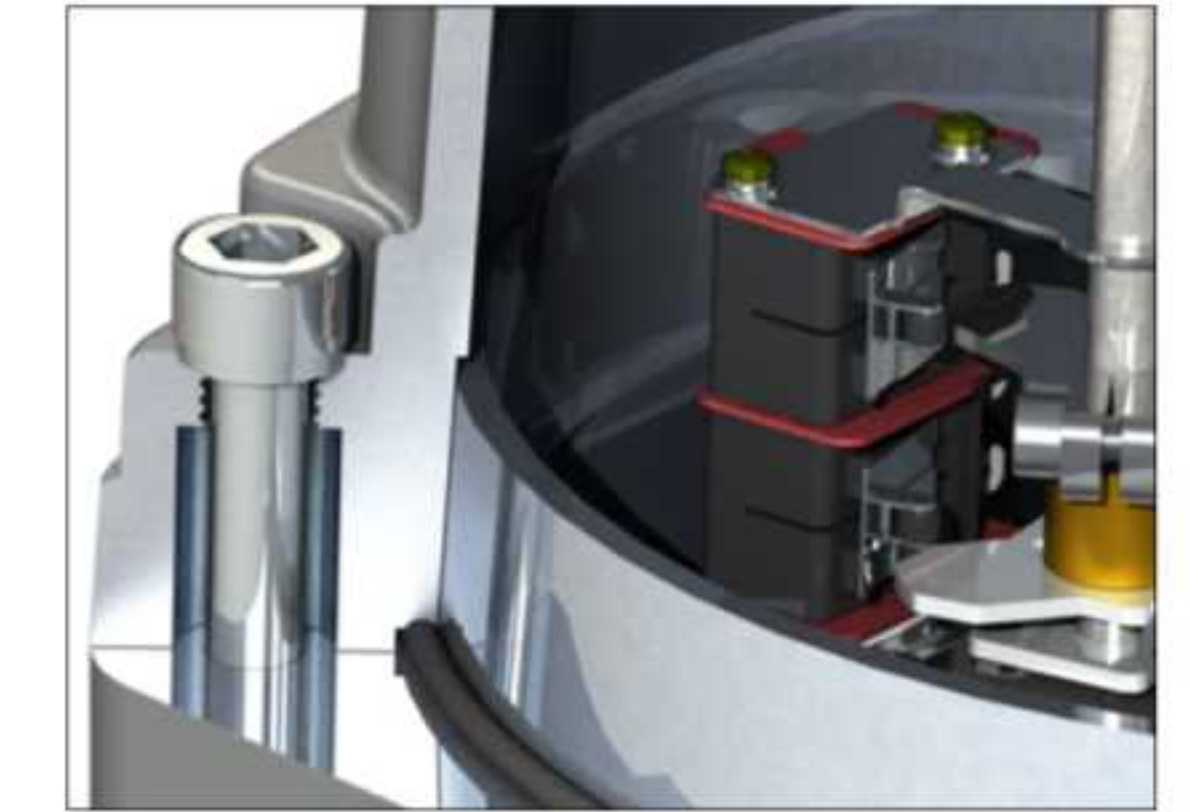

Interface of cover and housing

- For other actuators, the joint surface is vertical due to the connection between the upper cover and the housing. As the tolerance here is very small, it is not easy to remove the upper cover. The "AOX-Q" series actuator is designed as a 3° inclined plane here, which solves this problem.

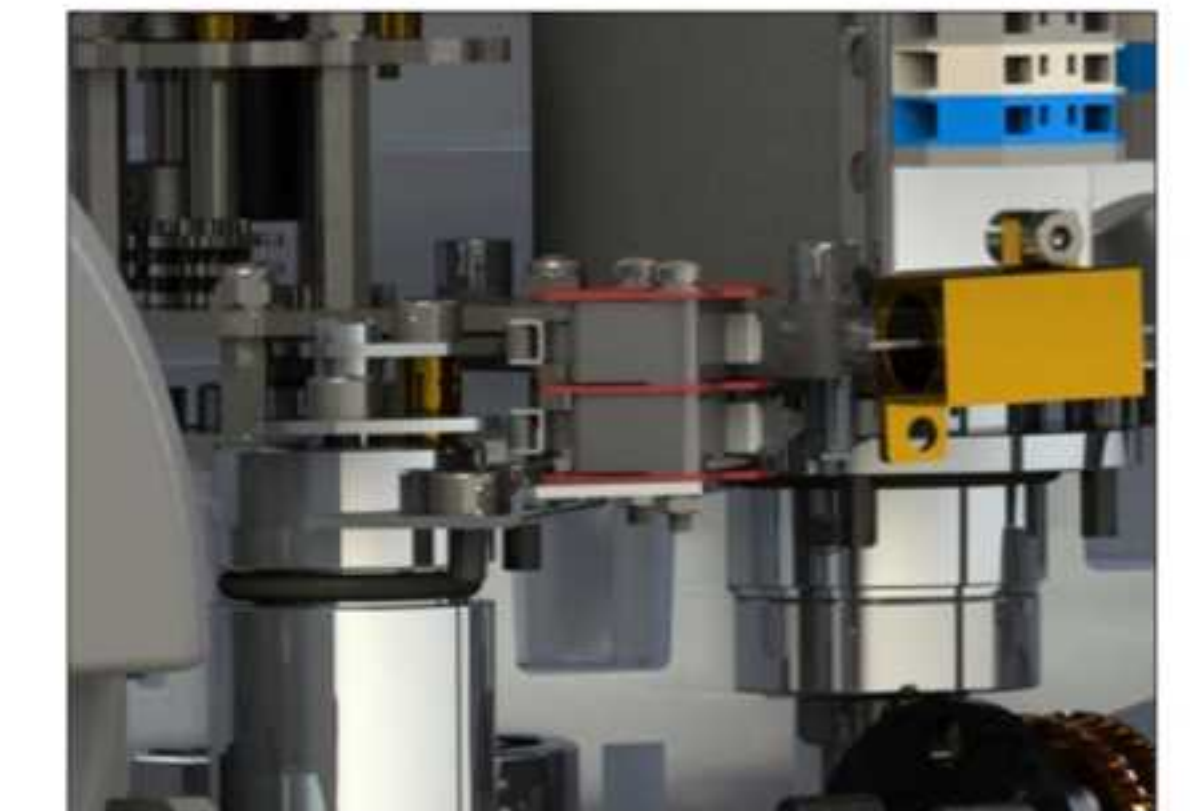

Torque switch

- Overload protection (except AOX-Q-L20/30/50/80) can be provided. When the valve is jammed and there are foreign matters, the motor power supply will be automatically disconnected, which can more effectively protect the valve and electric actuator from damage.

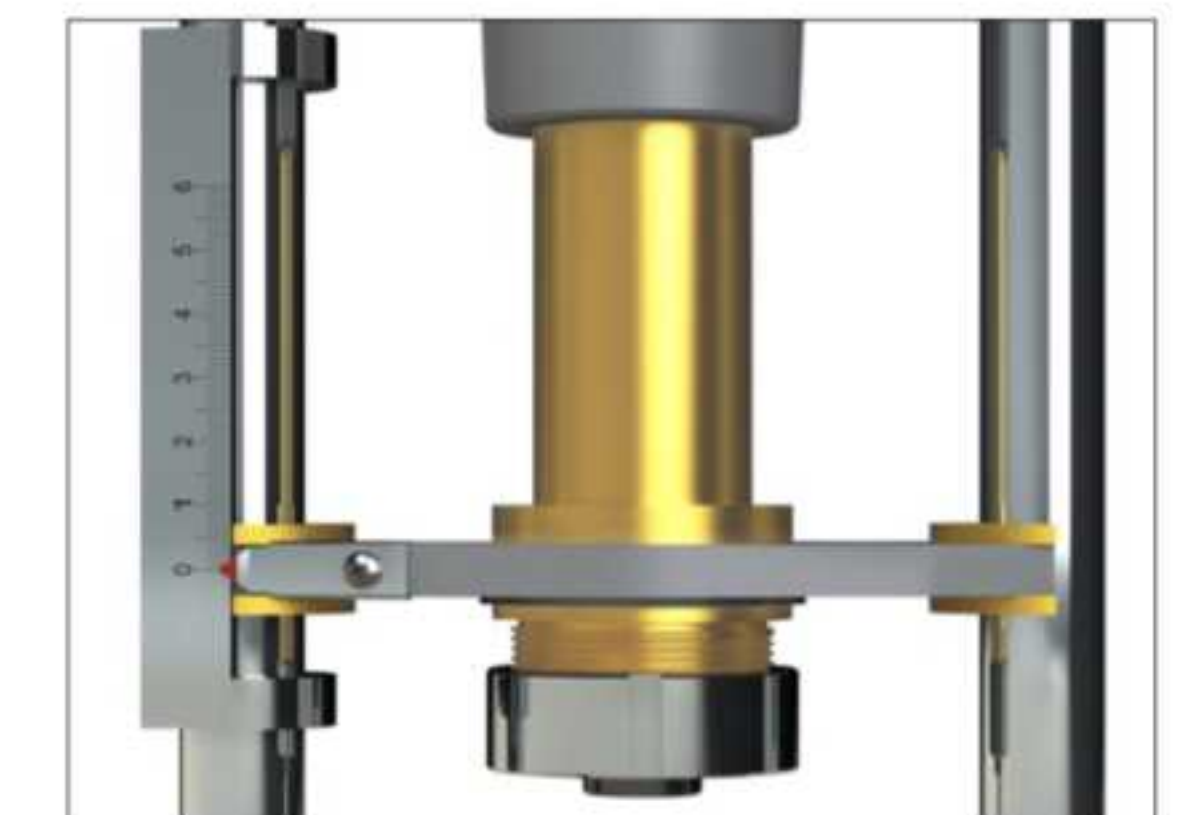

Valve position indicator

- The indicator is mounted on the support shaft, which is more convenient and intuitive to observe, and the position is adjustable.

1. Worm gear

- Copper alloy (material QAL10-4-4)

2. Self locking

- The precise double worm gear mechanism can efficiently transmit large torque, with high efficiency, low noise (maximum 50 decibels) and long service life. It should have self-locking function to prevent reverse rotation. The transmission part is stable and reliable, and no oil is needed.

3. Sealing

- Ip67 (standard) protection level, all connecting surfaces are sealed with O-ring, and IP68 (all connecting surfaces are equipped with one to three layers of O-ring) is optional.

4. Hand wheel

- As the torque of the actuator increases, the size increases. It is made of aluminum alloy to facilitate labor-saving operation, and the automatic clutch ensures safe operation.

5. Lubrication

- Use special lubricating grease for actuator.

Product Characteristics



Knob Package (Patent No.: ZL201120459658.0)

It is set independently of the actuator housing outside and fixed on the housing. Its front is equipped with a liquid crystal display and a rotary button, and its side is equipped with a positioning block. The positioning block can be rotatably set on the front of the rotary package. The rotating shaft of the positioning block is equipped with a torsion spring. Under the action of the torsion force of the torsion spring, the card of the positioning block is buckled into and close to the positioning notch of the rotary button to position and lock the rotary button. The electric actuator can be operated on site with LCD display and locking of operation function status, which makes the use of the electric actuator more humanized, reliable and wide in application.

LED and Module Box (Patent No.: ZL 201120459605.9)

The LED and module are installed in the external control box. The control box is set independently from the outside of the shell, so that the module is not affected by the motor temperature. LCD has the characteristics of low power consumption, long service life, high brightness, low heat and durability. The LCD screen interface can display text information, graphic elements and actuator characteristics, and can be set in the menu mode of man-machine conversation.



Omron Limit Switch

Omron electronic limit switch is adopted and controlled by cam mechanism. Simple adjustment mechanism can set the position accurately and conveniently.

Absolute Encoder

The absolute encoder is used to provide position accuracy. The absolute encoder can accurately and reliably record the valve position without battery when the actuator is powered off.



Gold Plated Connector

Gold plating can ensure the high stability, high conductivity, high temperature resistance of the connector, as well as excellent corrosion resistance and oxidation resistance, and can effectively avoid signal attenuation. Moreover, due to the wear resistance, ductility and other characteristics of gold, the plugging and unplugging times of connectors are greatly improved. It ensures high contact force after multiple plugging and unplugging, so as to better ensure conductivity and signal continuity.

Dual Channel Bus

The adoption of dual channel bus can improve the data transmission speed and enable the actuator to get more accurate response. When dual channel bus is used, even if the plug is unplugged, the bus communication remains smooth. When the bus terminal resistance is connected, the bus will be separated. This can be directly connected to DC24V power supply, and the bus and power supply wiring are separate.



Hand Wheel Locking Device

The start of manual operation can be controlled by the locking device. In other words, once manual operation is started, it cannot be automatically switched to electric operation mode.

Electric Machinery

The specially designed induction motor has large starting torque and high efficiency, and the built-in overheat protector prevents the motor from overheating and causing damage - insulation level H.



Bus Control

Reducing cost is the most critical factor for the wide application of fieldbus technology. In addition, the use of serial communication to control field devices and actuators in process automation is considered to be the most innovative way. The benefit improvement of the factory, such as remote parameter setting or factory asset management, cannot be achieved without fieldbus technology. AOX series electric actuators equipped with field bus interface have the most advanced technical level in the world.

AOX Fieldbus Device

Many different fieldbus systems have been widely used, and the accuracy of parameter setting is constantly being improved at a local level or in a specific field application. AOX series electric actuators are widely used in various process automation control fields around the world, and have established their application status in all field bus industries.

- ▶ Profibus DP
- ▶ Modbus RTU
- ▶ HART
- ▶ FF

In a word, AOX equipment has the communication ability to connect other binary and analog input signals to the field bus.

Communication - Bus

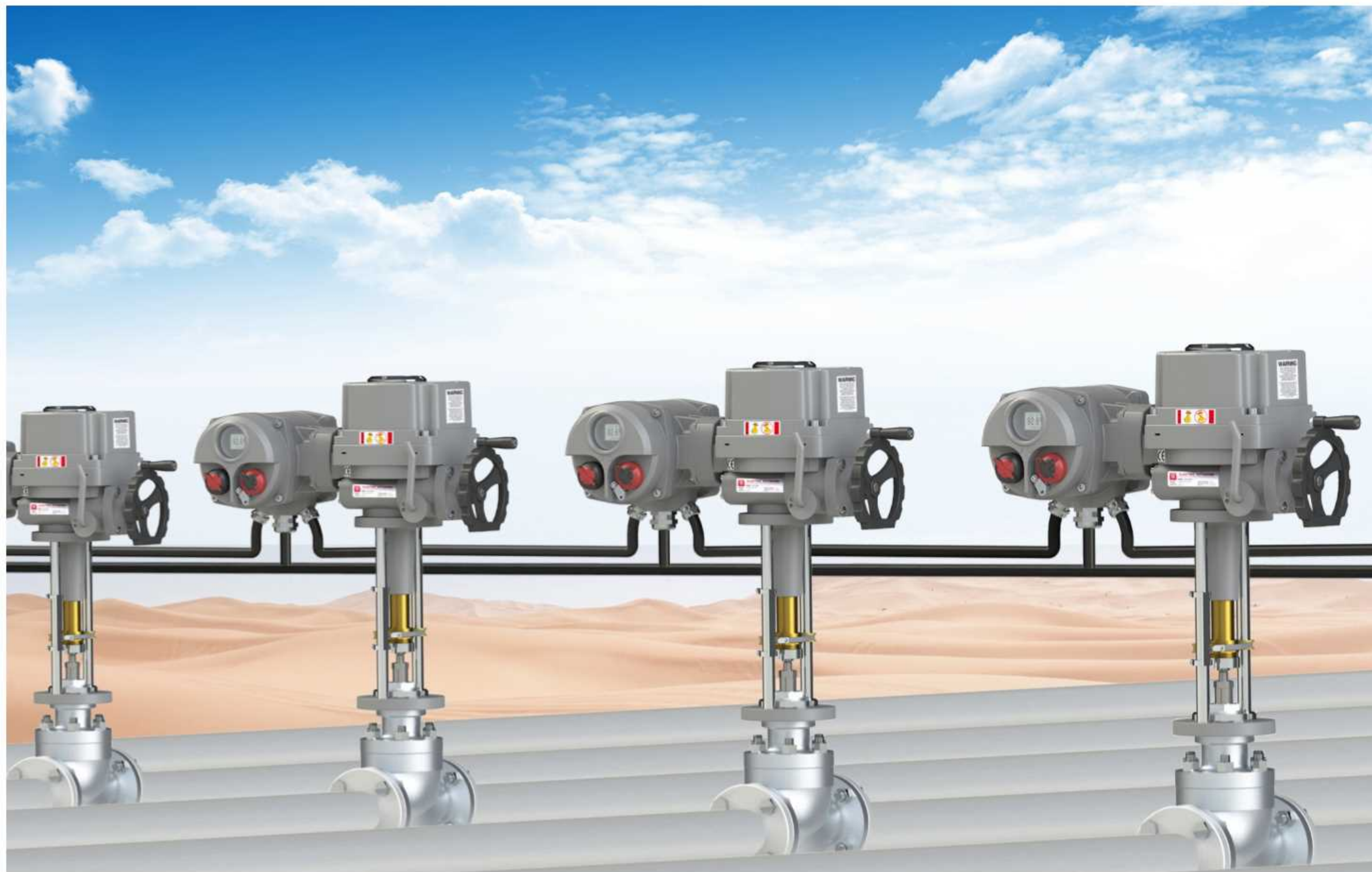

Profibus DP Protocol

Profibus is a perfect version of field bus: Profibus PA is used in the field of process control, and Profinet is a new generation of automation bus standard for data transmission based on Ethernet and Profibus DP, mainly used in plant power plants and automation equipment. Due to its simple and durable physical layer (RS-485) and different versions of DP-VO (fast cycle deterministic data exchange), DP-V1 (acyclic access to equipment parameters and diagnostic data) and DP-V2 (more functions such as time stamping or redundancy), Profibus Dp is the most ideal solution for modern chemical plant automation.

- ▶ Conform to international standard IEC 61158/61784 (CPF3)
- ▶ Large installed capacity
- ▶ Standardized integration in DCS (FDT, EDD)
- ▶ Wide range of equipment selection
- ▶ Typical application environment: power plant, sewage treatment, water purification, tank farm

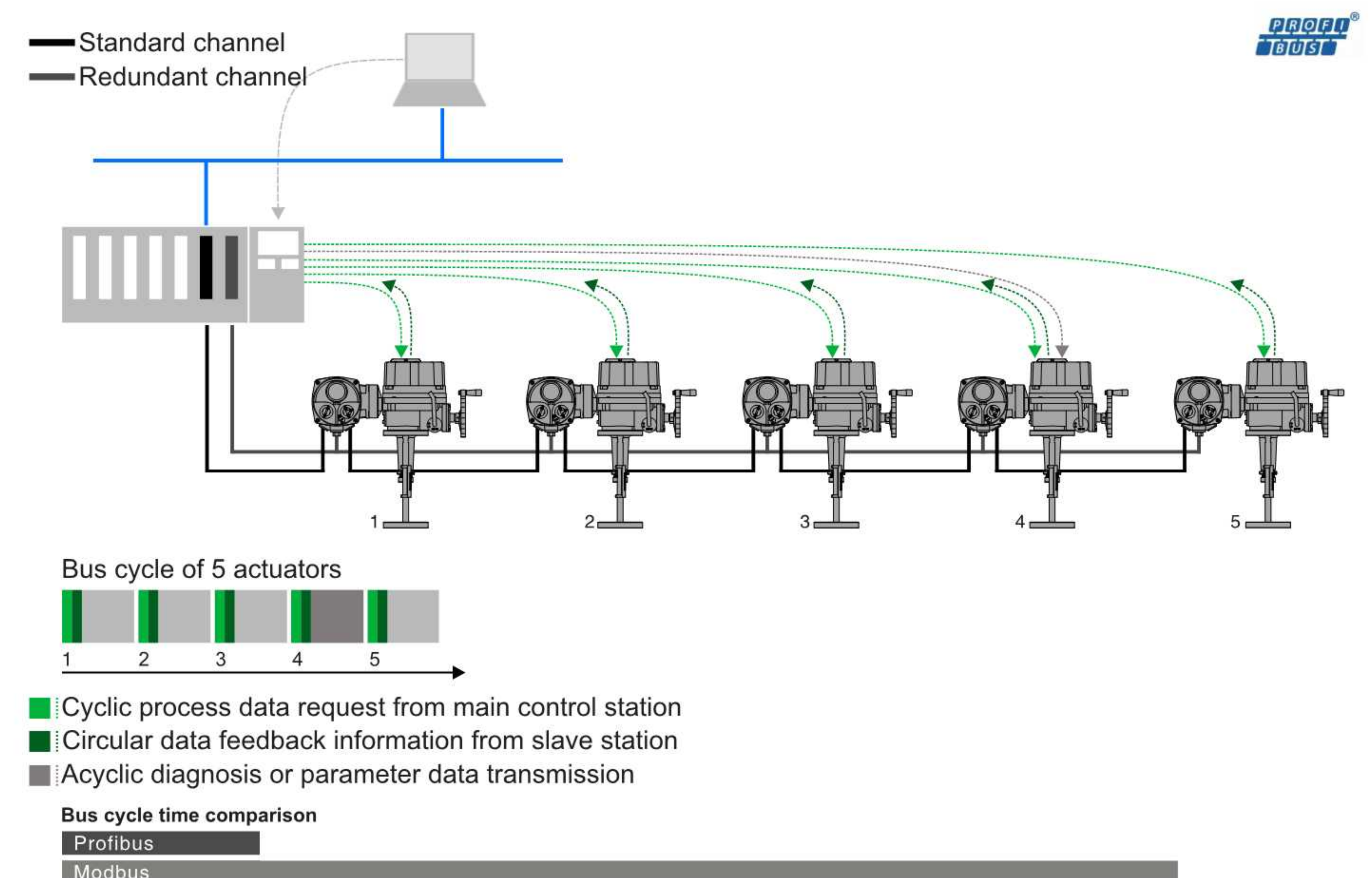

Modbus RTU Protocol

Compared with other field bus technologies, Modbus is a relatively simple but powerful field bus protocol. It can provide all services required by factory automation, such as simple binary information, analog information, equipment parameter information or diagnostic data exchange.

In the field of industrial automation, simple and stable RS-485 physical links are often used. Based on this physical link, Modbus supports multiple transmission modes, such as Modbus RTU or Modbus ASCII. The Ethernet based Modbus TCP/IP version is often deployed to the vertically integrated host automation system.

- ▶ International standard IEC 61158/61784 (CPF15)
- ▶ Simple protocol
- ▶ Global promotion and application
- ▶ Communication sufficient to complete multiple simple automation tasks
- ▶ Typical application environment: water treatment and sewage treatment, pump station, tank farm

AOX-Q-L Series Actuator Configured With Modbus RTU

- ▶ Fast data exchange
(up to 115,2 kbit/s - corresponding to approx. 20 ms/actuator)
- ▶ The cable length can reach about 10 km
(1200 m without repeater between two actuators)
- ▶ Up to 247 field devices can be connected
- ▶ Available: redundant linetype topology
- ▶ Optional: data is transmitted through optical fiber cable

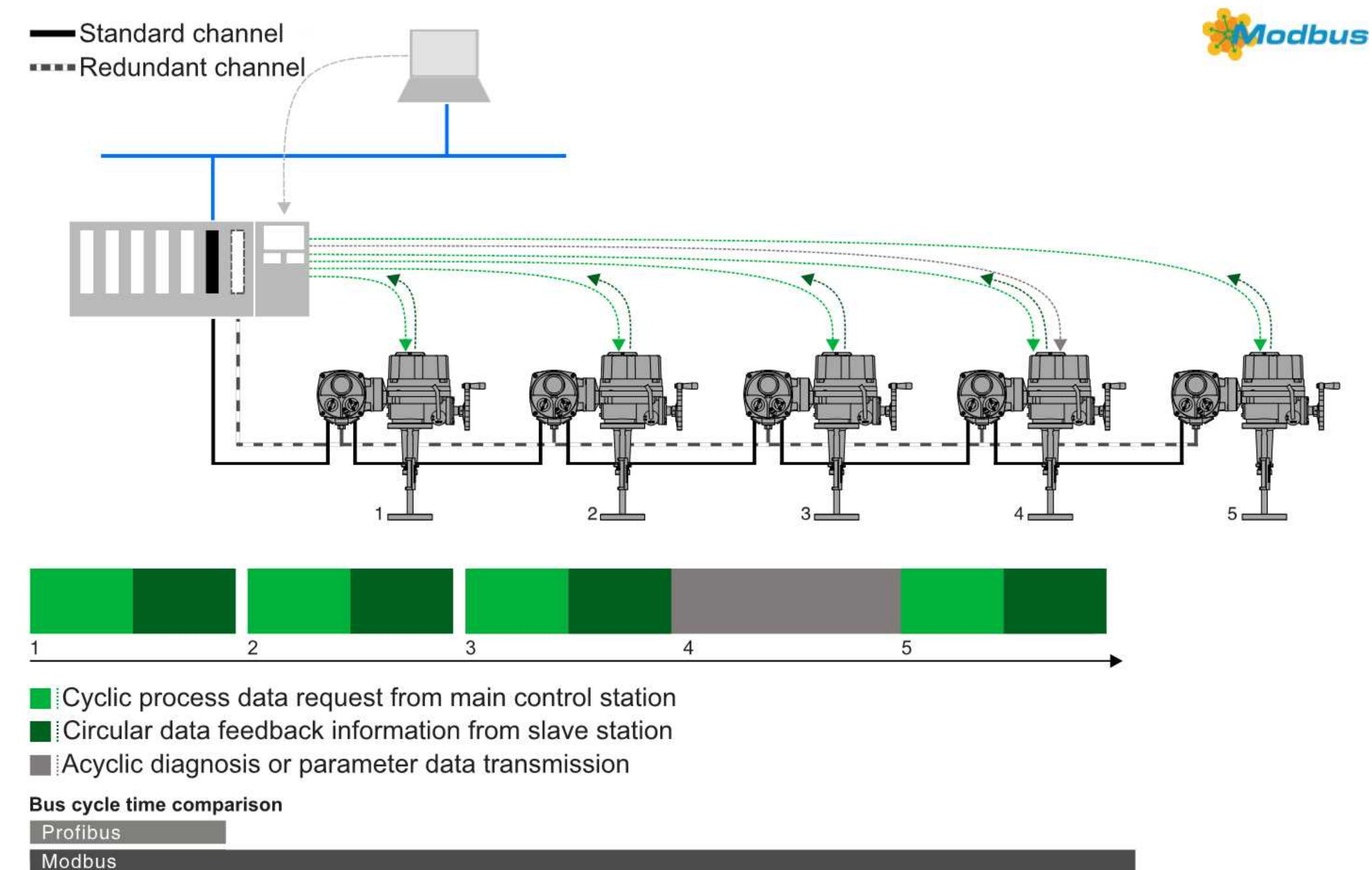

HART Protocol

HART uses 4-20mA standard signal to complete analog data transmission. HART communication is to superimpose digital signal on analog signal.

Advantages: HART protocol realizes synchronous transmission of digital signal and analog signal, that is, digital signal communication is completed in the existing 4-20mA analog system, and process parameters and diagnostic data can be easily read from field equipment at any time.

HART is designed based on the principle of master control station slave station, providing multiple instructions for data transmission. The traditional 4-20mA point-to-point wiring mode is usually used.

- ▶ International standard IEC 61158/61784 (CPF9)
- ▶ Global promotion and application
- ▶ Large installed capacity
- ▶ Standardized integration in DCS (FDT, EDD)
- ▶ Wide range of equipment selection

AOX-Q-L Series Actuators Configured With HART Protocol

- ▶ 4-20 mA HART analog signals are used to transmit setpoint signals or signals are alternately transmitted actual
- ▶ The position signal transmits process parameters and diagnostic data through HART digital communication
- ▶ Digital communication of each actuator is about 500 ms
- ▶ Communication with DCS via EDDL
- ▶ Cable length can reach about 3 km

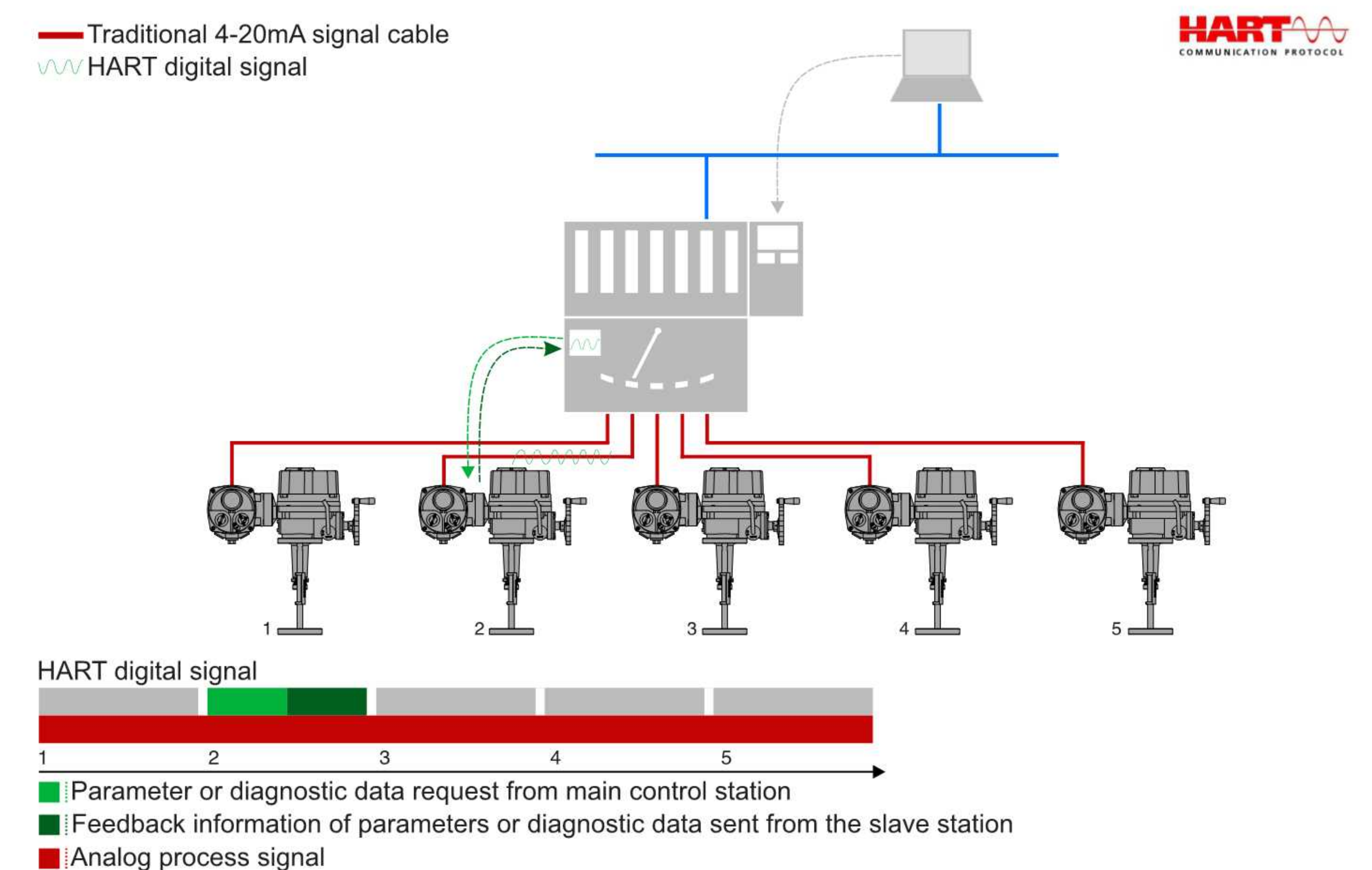

Product Specifications

General specifications	
Torque range	·Direct installation: 2000-40000N ·Larger or quick opening optional AOX-M series
Shell material	Hard aluminum alloy
Position indicator	Even in case of power failure, the valve position dial can display continuous position changes
Tightness	
External corrosion protection	Paint system ·Polyester powder coating conforms to GBT 18593-2001 standard ·Optional protection for highly corrosive condition ·Screws are all stainless steel screws
Travel/limit	
Travel	16~100mm(Other travel can be customized)
Limit switch	2×Open/Close, SPDT, 250V AC 10A
Auxiliary limit switch	2×Open/Close, SPDT, 250V AC 10A
Torque switch	On/Off,SPDT, 250V AC 10A(except AOX-Q-L20/30/50/80)
Mechanical specifications	
Self locking device	Worm gear and worm mechanism provide self-locking
Output flange	The bottom installation dimension shall conform to ISO5211 international standard
output shaft	The output shaft drive sleeve can be disassembled and machined for adaptability. Can be installed vertically or horizontally
Seismic performance	X YZ10g, 0.2~34 Hz, 30 minutes
lubrication	Molybdenum disulphide grease (EP type)
Manual operation	Mechanical clutch mechanism
Handwheel	Reliable, labor-saving, small size
Electrical specifications	
Motor power supply	110/220V AC 1Phase,380/440V AC 3Phase, 24V DC, 50/60Hz, ± 10%
Control power	110/220V AC 1Phase,50/60 Hz,±10%
Electric machinery	Squirrel cage asynchronous motor, insulation class H
Failsafe/Operating Temperature	Built in thermal protection, open/close 120 °C± 5 °C
Heater	30W(220V AC) Anti condensation
Cable entry	2x NPT 3/4" standard (three connection holes are optional)
EC Directive	
Conformity with EC Directives	The actuator meets the following requirements ·014/30/EU Electromagnetic Compatibility ·2014/35/EU Low Voltage The following harmonized standards ·General emission standard for industrial environment EN 61000-6-44 ·Rotating electrical machine standard EN 60034-1 ·General anti-interference standard for industrial environment EN 61000-6-4

Standard Parameters

Model	Thrust N	Speed mm / s	Maximum Stroke mm	Motor (H) W	Rated current(A)50Hz					Weight KG
					1 Phase		3 Phase		DC	
					110V	220V	380V	440V	24V	
AOX-Q-L20	2000	0.66	60	20	1.62	0.49	0.28	N/A	6.43	18
AOX-Q-L30	3000	0.66	60	20	1.62	0.52	0.28	N/A	6.45	18
AOX-Q-L50	5000	0.66	60	20	1.62	0.54	0.32	N/A	6.47	18
AOX-Q-L80	8000	0.33	60	20	1.62	0.61	0.32	N/A	6.49	18
AOX-Q-L100	10000	0.50	60	40	1.75	0.73	0.36	0.31	7.60	30
AOX-Q-L160	16000	0.50	60	40	1.75	0.89	0.43	0.31	8.05	32
AOX-Q-L200	20000	0.50	100	90	3.70	1.39	0.49	0.34	7.20	33
AOX-Q-L250	25000	0.50	100	120	2.86	1.87	0.58	0.58	14.5	34
AOX-Q-L300	30000	0.50	100	120	2.86	1.95	0.62	0.59	14.7	35
AOX-Q-L350	35000	0.44	100	180	3.85	1.75	0.85	0.86	17.5	38
AOX-Q-L400	40000	0.44	100	180	/	1.98	0.87	0.88	/	38

The above time is the regular time of the actuator. If you need special time, please contact our company.

Appearance Drawing

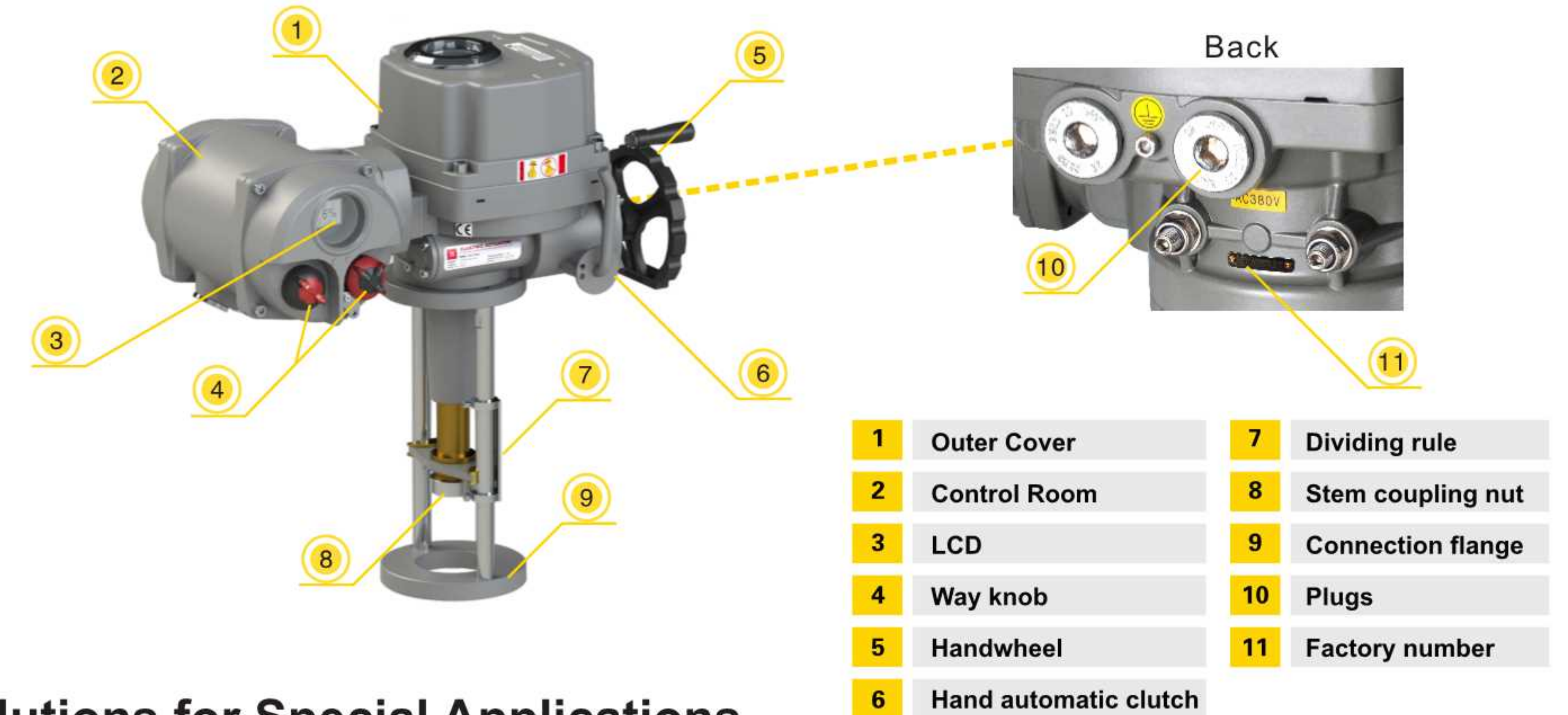

Solutions for Special Applications



Split type

The control unit with control function can be individually split-mounted when the valve is installed in a location that is difficult for personnel to access or where there is extreme vibration or ambient temperature. The cable length between the actuator and the control unit can be up to 100m, and the split can be easily reinforced or relocated at any time.

Free adjustment of the mounting position

The optimum mounting position can be adjusted to avoid upside down displays, inoperability, uneven cable sealing of the control unit, etc. The appropriate position can be easily selected.

Adjustment of the control unit components per 90° rotation is possible: between the control unit and the actuator, between the local control interface and the control unit, and between the electrical connection and the control unit. The electrical connections make it easier to adjust the installation position in the field.



Power off reset

When the power supply fails, it will act according to the factory set valve position. The rechargeable lithium battery cell with large capacity, long service life and high power is adopted, which requires short charging time, can be continuously charged for 5W times, and is green, efficient and energy-saving. (Note: it will vary according to the functional voltage profile)

Backup power

- ▶ High performance lithium battery

Number of continuous transmission after power loss

- ▶ ≥ 5 full strokes